

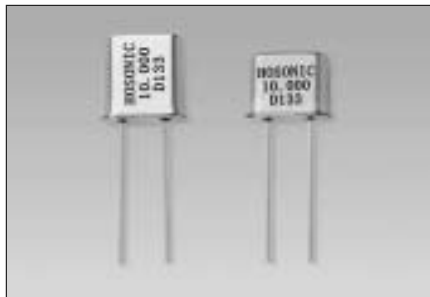

• UM-1 & UM-5 Series



The UM-1 and UM-5 crystal units are miniature resistance welded package that provides excellent hermetic seal and frequency aging. The frequency range till 125Mhz and miniature size is ideal for communication equipment.

FEATURES

- Low cost
- Industry Standard
- Wide Frequency Range
- Small Compact Size
- High Stability
- 'AT' Cut Crystal

Electrical Specifications

Parameter	Symb	Condition	Min	Typ	Max	Units
Frequency Range	F ₀		10		125	MHz
Frequency Tolerance	ΔF/ F ₀	AT 25°C		±10	±50	ppm
Temperature Stability	TC	See table 1		±10	±50	ppm
Operating Temperature Range	T _{OPR}	See table 1				°C
Storage Temperature Range	T _{STG}		-40		+85	°C
Shunt Capacitance	C ₀				7	pF
Load Capacitance	CL	Customer Specified	10		Series	pF
Insulator Resistance	IR	100V _{DC}	500			MΩ
Drive Level	DL			100	500	μW
Aging	F _a	AT 25°C, per year	-5.0		+5.0	ppm

Equivalent Series Resistance(ESR) and Mode of Vibration(Mode)

Frequency Range(Mhz)	Max ESR(Ω)	Mode
10.000 to 12.999	60	Fundamental
13.000 to 19.999	40	Fundamental
20.000 to 29.999	30	Fundamental
30.000 to 39.999	60	3 rd Overtone
40.000 to 59.999	50	3 rd Overtone
60.000 to 79.999	50	3 rd Overtone
80.000 to 125.000	100	5 th Overtone

Temp Range(°C)	Frequency Stability(PPM)					
	±5	±10	±15	±20	±30	±50
0 to 50	✓	✓	✓	✓	✓	✓
-10 to 60	✓	✓	✓	✓	✓	✓
-20 to 70		✓	✓	✓	✓	✓
-40 to 85				✓	✓	✓

Mechanical Dimensions(mm)

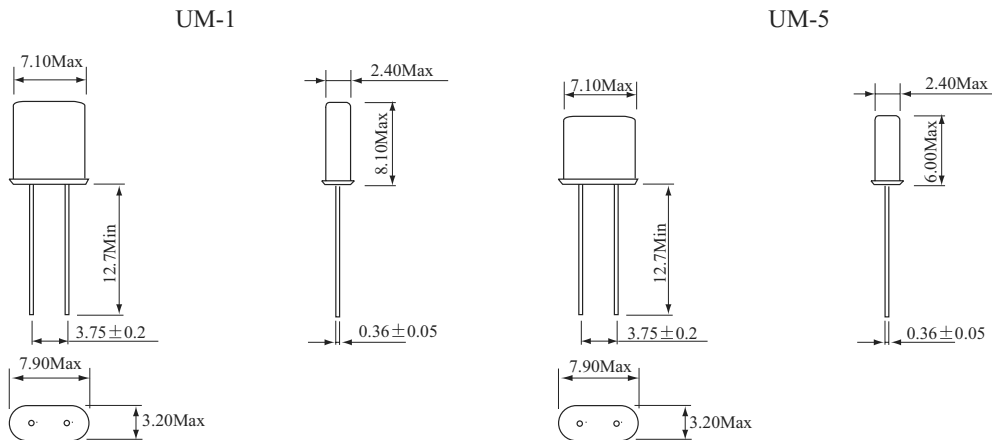

TAIWAN:
HOSONIC ELECTRONIC CO., LTD.
23-1 LANE 84. CHUN YING ST. SHULIN CHEN.
TAIPEI 23804. TAIWAN. R.O.C.

☎ : 886-2-86875200
☎ : 886-2-26816456

WEB SITE:<http://www.hosonic.com.tw>

CHINA:
HANGZHOU HOSONIC ELECTRONIC CO., LTD.
XUNSHAN LIANGZHU TOWN MOGANSHAN ROAD
HANGZHOU, ZHEJIANG, CHINA

☎ : (86)-571-88778189
☎ : (86)-571-88778857

Specifications are subject to change without notice